

surefire lathe tool sharpening

A nifty jig slays
the sharpening dragon.

To help avoid tool catches, torn grain, and other turning snafus, it's essential that your tools be properly sharpened. So how do you do that? We asked three professional turners (see page 95 for more on them), and their answers were unanimous: "Get a Wolverine Grinding Jig." All three felt that next to a solid lathe and a good set of

tools, the Wolverine Grinding Jig by Oneway is the best investment an amateur or occasional turner can make.

Next, we asked our pros how to put the Wolverine Jig to best use. Here's what they showed us.

First, let's get familiar with the jig

The complete sharpening system, shown *left*, includes the Wolverine Grinding Jig, consisting of two locking bases, a V-arm rest, and an adjustable platform rest (about \$80), and two accessories: the Vari-Grind Attachment (about \$48) and Skew Grinding Attachment (about \$27).

Use the V-arm rest by itself to sharpen your roughing gouge and parting tool. It also supports the Vari-Grind Attachment, used for putting the popular side grind on bowl gouges and fingernail grind on spindle gouges. To sharpen your

skew chisel, clamp the Skew Grinding Attachment to the V-arm rest. The platform rest accommodates the sharpening of scrapers, and also makes an excellent rest for sharpening other edge tools, such as plane irons and chisels.

Adjustable locking bases secure the rests for proper tool positioning. This also allows you to grind on either wheel with both rests. The bases mount directly under the grinding wheels, as shown on **Drawing 1**, so make sure your grinder accommodates them. To elevate the center of the grinding wheels to the height shown, insert a spacer block between the grinder and its platform.

You may find the prospect of spending \$160 for a jig to sharpen your lathe tools daunting. That's about the cost of five mid-priced M2 high-speed steel tools. But if they're not sharpened properly, even the most expensive tools aren't much good. The Wolverine Jig allows

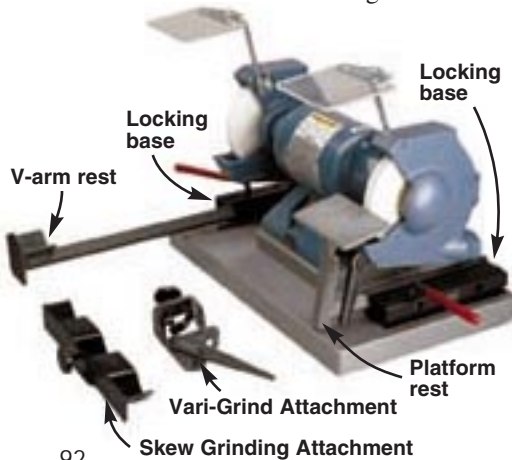

SHOP TIP

How to ensure perfect tool-to-grinding-wheel alignment

Accurate alignment of a tool's bevel with the grinding wheel means less metal removed when sharpening. You'll also avoid a gradual drift away from that perfect bevel you've established. Aligning the bevel to the wheel by eye doesn't always get perfect results. Here's a trick that will.

Blacken the bevel of the tool with a permanent felt-tip marker. Adjust the tool rest, and align the tool's bevel with the wheel by sight. Switch on the grinder, and barely touch the tool's bevel to the wheel. In the photo, *right*, the shiny spot shows that the bevel's heel contacted the wheel first. Readjust the tool rest so the wheel removes the marker all the way from the bevel's heel to the cutting edge.

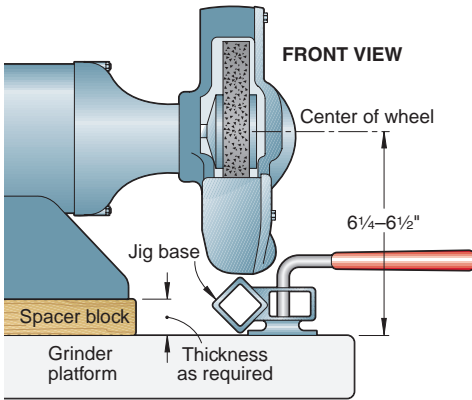

1 JIG SETUP

you to do what most people can't do by hand: grind smooth, consistent bevels to precise angles without the multitude of facets typical of freehand attempts.

What you need to know about grinders and wheels

Most general-purpose grinders run at 3,450 rpm and come equipped with gray utility wheels. This combination of high speed and hard wheels easily overheats lathe tools, leading to short edge life. Our experts recommend an 8" slow-speed grinder (1,725–2,000 rpm) equipped with white aluminum oxide wheels. These wheels are designed to wear away during sharpening, constantly exposing new cutting particles. This results in cooler, more efficient grinding. Fit your grinder with one 60-grit wheel for rough shaping your tool profiles when needed, and one 100-grit wheel for routine sharpening.

If you already have a 3,450-rpm grinder you don't have to replace it; fitting it with white aluminum oxide wheels is more important than slow speed. Also, a 6" grinder is acceptable, but no matter which size grinder you use, replace the wheels when they wear down to about 5" in diameter.

You'll need to keep the wheels dressed to remove metal particles and maintain flat surfaces. Oneway offers the Wolverine Dressing Jig (about \$65), and most woodworking and turning supply catalogs offer inexpensive diamond wheel dressers (\$16 to \$40).

For best results, use light grinding pressure, and move the tool from side-to-side to avoid wearing furrows in the wheels. For safe operation when using the V-arm rest, keep the tool's contact point well above the grinding wheel's centerline. When using the platform

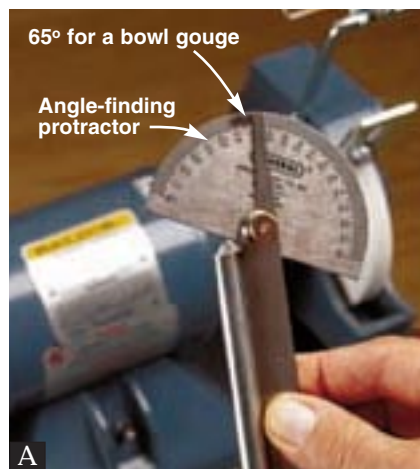

rest, position its leading edge about 1/8" from the wheel. Make all jig adjustments with the grinder stopped.

Setting up the jig

Note: Drawing 2 shows the various parts of a bowl gouge tip. Although the geometry of spindle and roughing gouges is different, the parts have the same names. Adjusting the Wolverine Jig to help you grind the angles described in the next section is easy. First, set an angle-finding protractor to the desired angle, and compare the tool's existing bevel to it, as shown in **Photo A**. This helps you form a mental picture of where to grind away metal. Then position the tool in the appropriate rest with its bevel contacting the grinding wheel. Adjust the rest to grind the bevel to the desired angle, and grind just enough to start forming a bevel. Check the angle with the protractor, and adjust the rest as necessary. With a couple of tries, you'll be right on the mark.

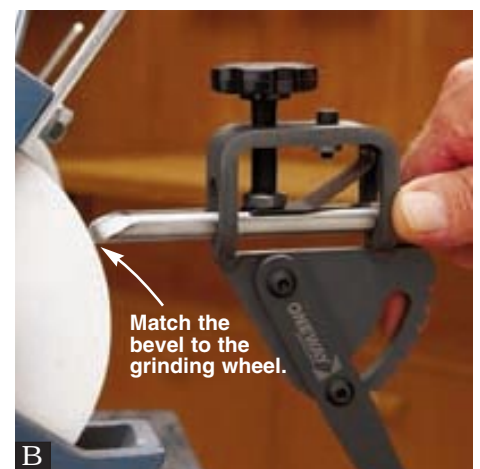

Once you've established the proper bevels on your tools, you'll be able to match them to the grinding wheel when adjusting the jig, greatly speeding the process. Simply touch the bevel to the wheel, sight it from the side, as shown in **Photo B**, and make the necessary adjustments. To perfectly match an existing bevel to the grinding wheel, see the **Shop Tip**, above. Occasionally check your bevels with the protractor to keep the cutting edges within 2–3° of the angles shown on **Drawings 3–9**.

2 PARTS OF A BOWL GOUGE TIP

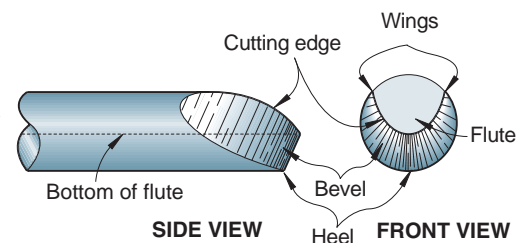

How to sharpen 6 basic turning tools

Roughing gouge

Position your roughing gouge with the end of its handle in the V-arm rest and its bevel on the grinding wheel. Adjust the V-arm to grind a 45° bevel, where shown on **Drawing 3**. Touch the roughing gouge's bevel to the wheel starting at the wing on one side of the flute. Roll the bevel across the grinding wheel all the way to the opposite wing in a continuous motion, as shown in **Photo C**. Maintain the 90° tip shown on the drawing.



3 3/4" ROUGHING GOUGE

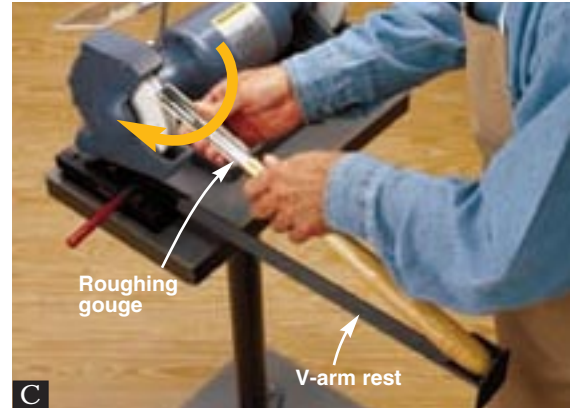
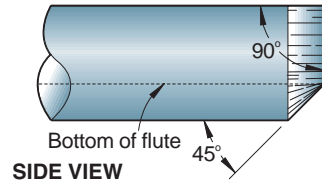

Bowl and spindle gouges

Bowl and spindle gouges come from the factory with a variety of grinds, some with limited uses and others not usable at all until they are reground. With more cutting edge and less chance of catching, a side grind on these gouges is becoming very popular. (In a side grind, the bevel extends back from the tip along the tool's side, in contrast to the "straight around" bevel on a roughing gouge.) Because of the wide range of motion required, this grind takes a lot of practice to execute freehand. Fortunately, the Vari-Grind Attachment for the Wolverine Jig makes it possible with little practice.



4 1/2" BOWL GOUGE

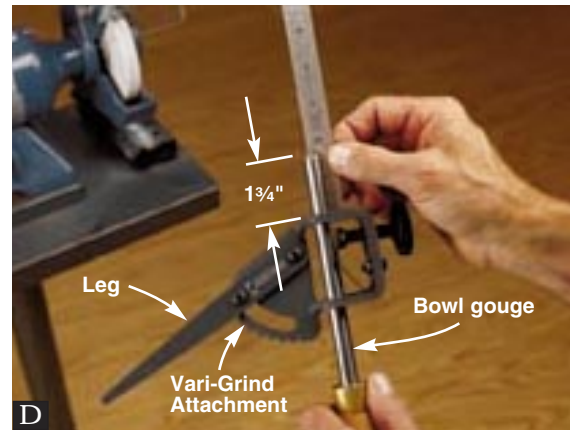
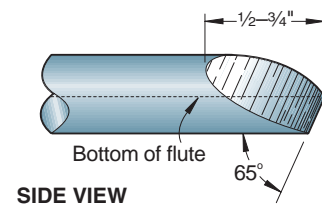

To sharpen bowl and spindle gouges, clamp the tool in the Vari-Grind Attachment with 1 3/4" protruding, as shown in **Photo D**. Place the attachment's leg in the V-arm rest, and touch the tool's tip to the wheel. Adjust the rest and the angle of the leg to grind the bevels shown on **Drawings 4** and **5**. With the grinder off, touch the tool's bevel to the wheel, and practice moving the tool from side to side to get comfortable with the motion needed to successfully sharpen your gouges. Now switch on the grinder, and gently touch the tool to the wheel, rolling it from side to side, as shown in **Photos E** and **F**.



5 3/8" SPINDLE GOUGE

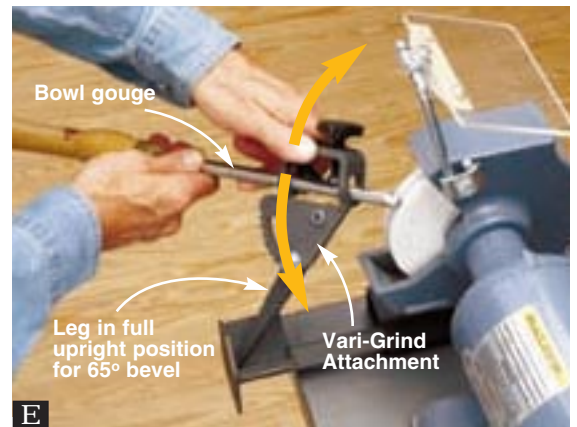
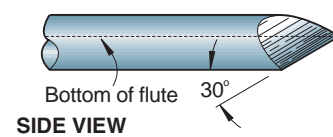

Roll the bowl gouge far enough to each side to grind the flute's wings back about 1/2-3/4" from the tool's tip, as shown on the drawing. Examine the bevel from the side. Look for a smooth, slightly convex profile, shown on **Drawing 6**. A slightly concave profile leaves the flute's wings protruding beyond the center of the cutting edge, making the gouge prone to catching in your work. Correct a concave profile by removing more material from the wings and the heel.

6 BEVEL SHAPE

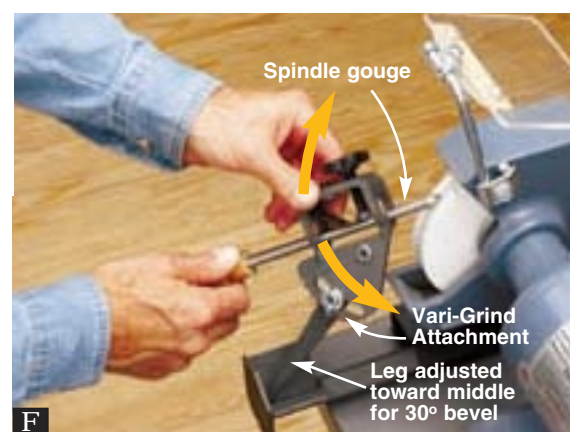
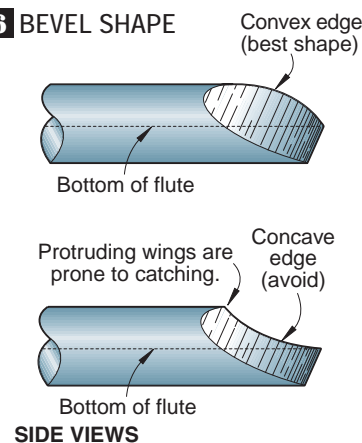

Skew chisel

The cutting edge of a skew chisel is typically angled at 70°, and sharpened to a 20° bevel, as shown on **Drawing 7**. If the angle of your skew needs correcting, adjust the platform rest so the skew points directly at the grinding wheel's center, and grind the 70° angle. With the end profile formed, attach the Skew Grinding Attachment to the V-arm rest. Place the skew in one of the attachment's V-rests with its toe pointing toward the opposite side, as shown in **Photo G**. With the bevel touching the wheel, adjust the arm to grind a 20° bevel. Move the cutting edge side-to-side across the wheel. Flip the tool over, and shift it to the other V-rest frequently to keep the edge centered in the tool's thickness.



7 SKEW CHISEL

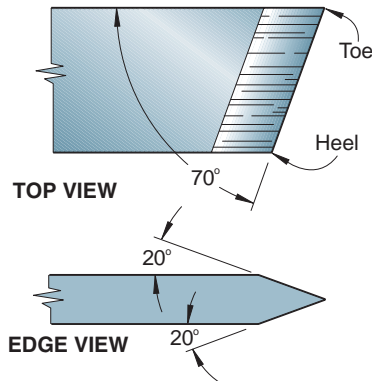

Roundnose scraper

Scrapers are usually ground to a 75° bevel, as shown on **Drawing 8**, so adjust the platform rest to grind this angle. When sharpening a roundnose scraper, start at one side, and grind the bevel all the way to the other side in one continuous pass, as shown in **Photo H**. Make repeat passes until you form a uniform bevel. Avoid a back-and-forth motion.



8 ROUNDNOSE SCRAPER

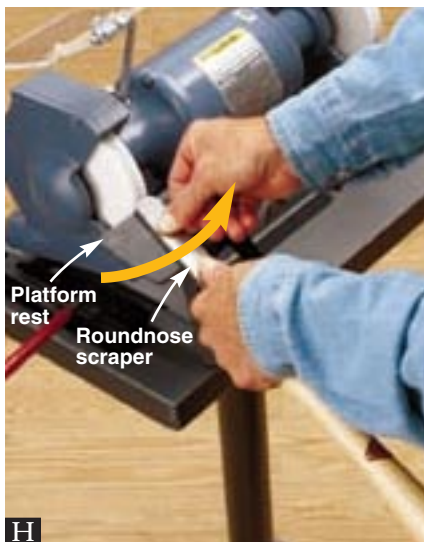
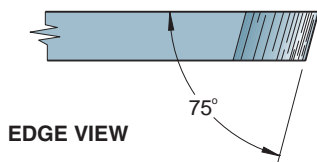

Diamond parting tool

Although some variations exist, a 60° point on a parting tool, shown on **Drawing 9**, is common. To sharpen the tool, place its handle in the V-arm rest with one of the point's edges touching the wheel. Adjust the V-arm to grind a 30° bevel. Now lightly press straight down on the tool and move it side-to-side across the width of the grinding wheel, as shown in **Photo I**.



9 DIAMOND PARTING TOOL

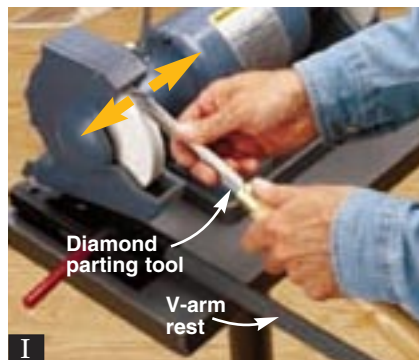
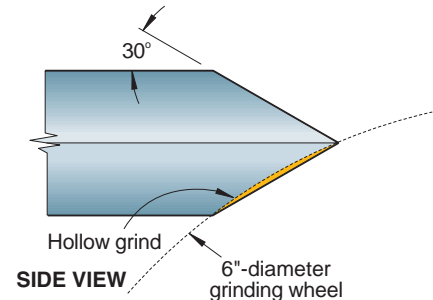

Flip the tool over frequently, lightly grinding both the point's edges until the ground faces intersect at the wide center of the tool. Due to the curve of the grinding wheel, you'll get a point with a slight hollow grind, as shown in the drawing. 🌳

Buying Guide

Wolverine sharpening system, white aluminum oxide grinding wheels, diamond wheel dressers.

For information and prices, call for catalogs, or visit the Web sites listed:

Craft Supplies USA. Call 800/551-8876, or go to www.woodturnerscatalog.com.

Packard Woodworks. Call 800/683-8876, or go to www.packardwoodworks.com.

Woodcraft. Call 800/225-1153, or go to www.woodcraft.com.

Protractor. Look for the General no. 18 angle-finding protractor at your local hardware store or home center. About \$12.

Written by Jan Svec with Phil Brennon, Rex Burningham, and Brad Packard

©Copyright Meredith Corporation 2003

Meet our experts



Phil Brennon

Currently president of the American Association of Woodturners, Phil teaches turning at Yavapai College in Prescott, Arizona, and sells his work in various galleries.



Rex Burningham

A turning teacher at Craft Supplies USA in Provo, Utah, Rex exhibits his work in galleries and craft shows. He has assisted Richard Raffan, Rude Osolnik, Dale Nish, and Ray Key.



Brad Packard

Engaged in professional woodwork, millwork, and woodturning for 20 years, Brad is a turning instructor and the owner of Packard Woodworks, a woodturning supply company.