

# Four Ways to Attach a TableTop

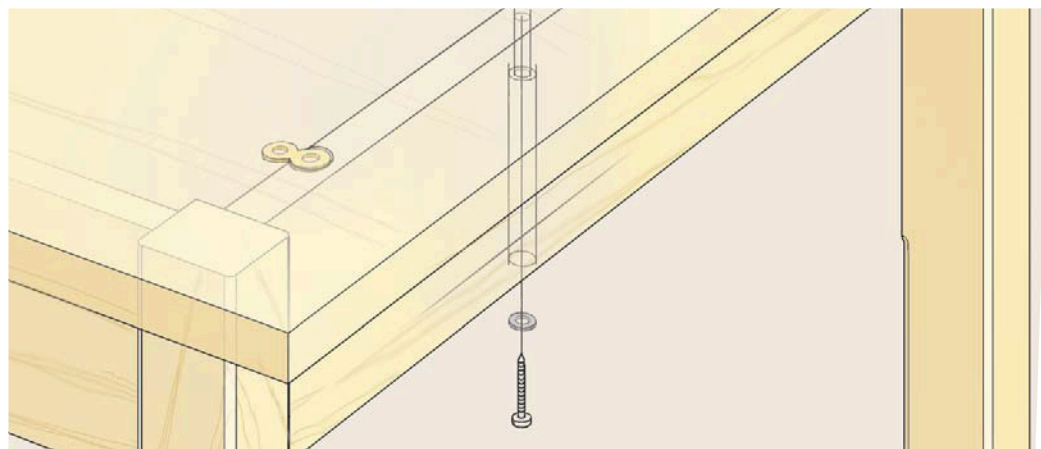

**Figure 8 Fasteners**

## Screws & Washers

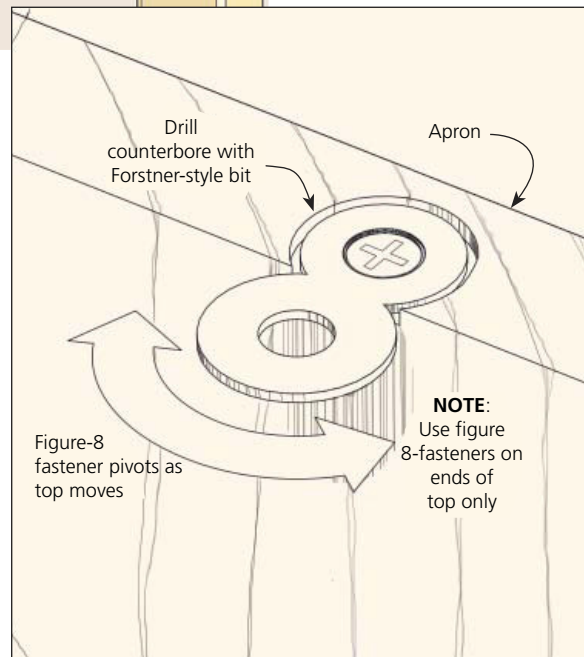
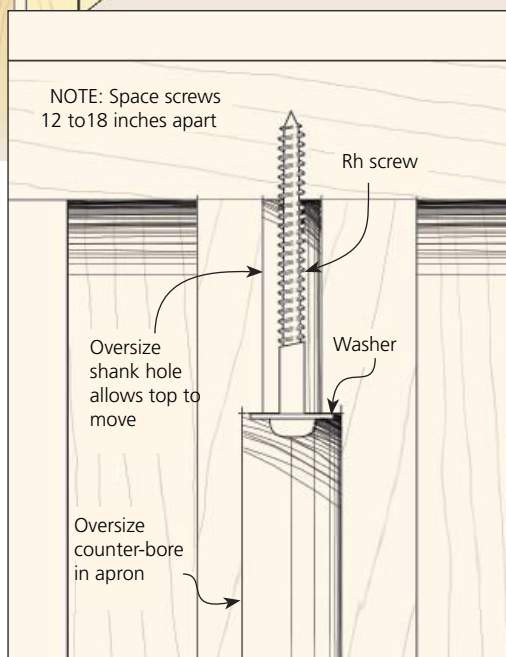

There's no substitute for traditional joinery when it comes to fine furniture building. Nails, screws, and other mechanical fasteners just don't hold a candle to a well-executed woodworking joint. But there's one situation where it's nearly impossible to avoid mechanical fasteners, and that's when you're attaching a table top.

**WOOD MOVEMENT.** Attaching a solid-wood top to a table presents an unusual challenge. On one hand, you want to make sure

the top is securely fastened so that it won't accidentally come loose if someone lifts the table by the top alone. But since the top will expand and contract with seasonal changes in humidity, you also have to fasten it to the base in such a way that it can "move" without splitting or cracking.

At first, these two goals might seem contradictory. But there are actually several ways of attaching a top that still allow the top some "breathing" room.

**SCREWS.** The simplest way is to screw the top directly to the base. This usually involves driving screws up through an apron or rail into the underside of the top. In order to give the top some room to move, I drill oversize shank holes for the screws, as shown in the detail drawing above. This way, as the top shrinks or expands, the screws have a little "wiggle" room.

**FIGURE-8 FASTENERS.** Another method of allowing for expansion and contraction

# How-To: Choosing a Screw

Almost as important as the type of hardware you use is the type of screw you use with it. Most wood screws have threads along only a portion of their shank. But sheet metal screws are threaded along the entire length of the shank. So they “bite” into the wood a little more for a stronger grip.

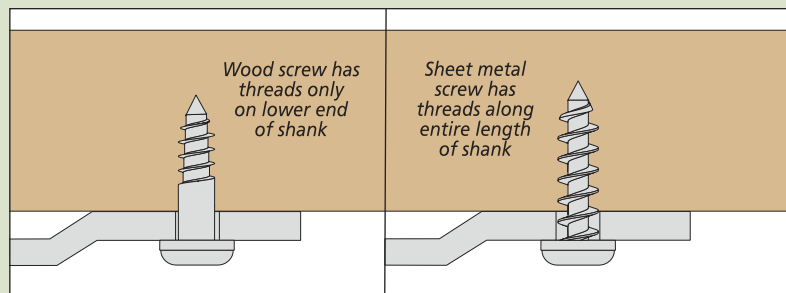

of a table top are figure-8 fasteners. These fasteners are inexpensive and fairly easy to install. You simply drill a shallow mortise in the top edge of the apron, screw the fastener in place, and then attach the top. The shape of the fasteners allows them to pivot as the top expands and contracts. You can use these fasteners on

the inside or the outside of the apron, depending on accessibility and whether or not you object to them being seen.

**TURNBUTTONS.** Screws and figure-8 fasteners are both quick and easy methods for attaching a top. But for heirloom-type projects, I like to use a couple of different methods for attaching the top.

One method is to use traditional hardwood turnbuttons, see below. These are nothing more than small blocks of wood with a tongue on one end. The tongue fits into a shallow groove that's cut on the inside face of the aprons. As the table top expands and contracts, the turnbuttons are free to slide within the groove.

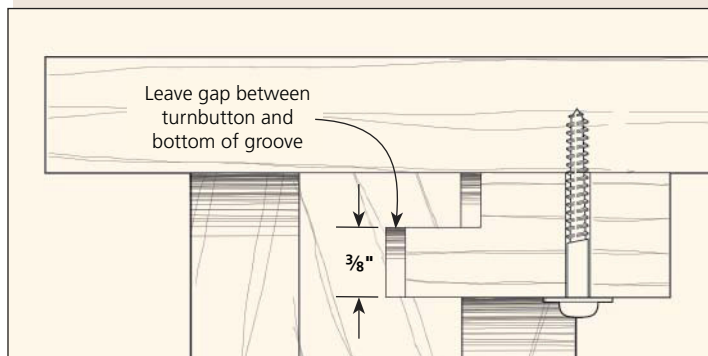
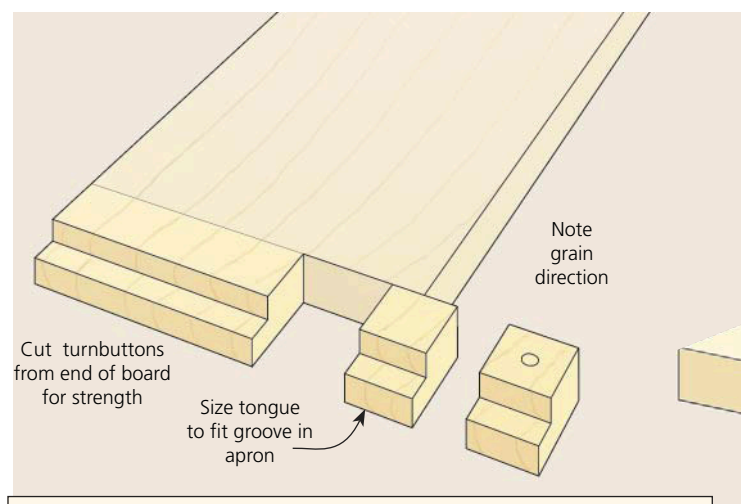

## Hardwood Turnbuttons

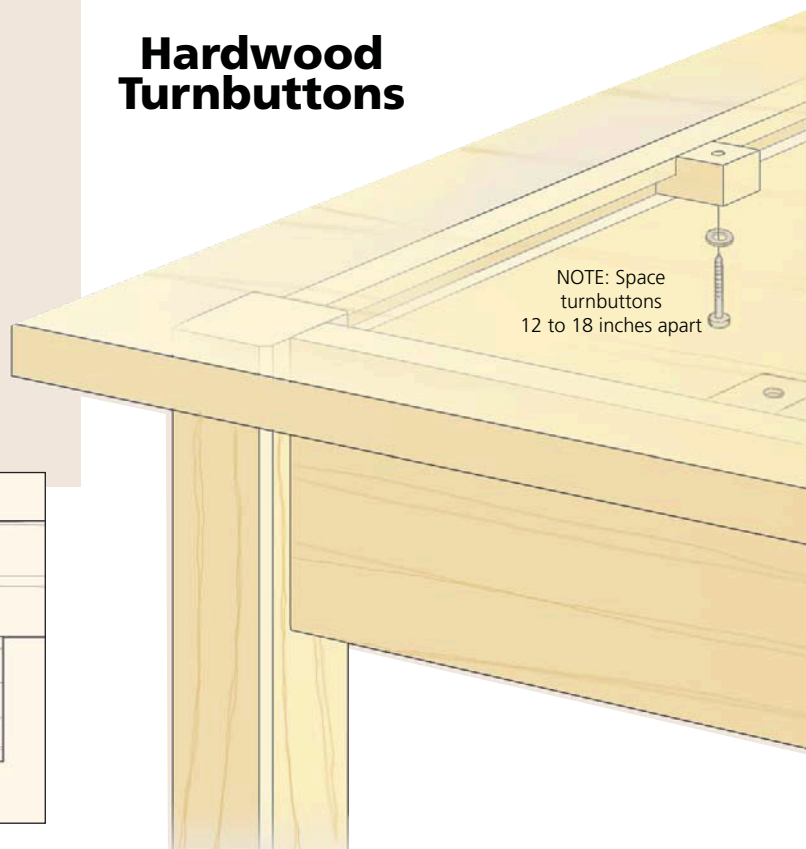

**Z-FASTENERS.** Z-fasteners are really just a metal version of the turnbutton (see drawing below). In this case, the fastener fits into a narrow kerf that is cut in the inside face of the apron. But they

work the same way. They hold the top securely to the base of the table, but they can still shift laterally within the kerf, allowing the top to move.

Regardless of which method you

choose, it's a good idea to periodically check and tighten the screws holding the top to the table. Over time, the expansion and contraction of the top can work them loose. **W**

## Z Fasteners

